



UNIVERSITY COLLEGE TATI (UC TATI)

FINAL EXAMINATION QUESTION BOOKLET

COURSE CODE	: DTD 1013
COURSE	: TECHNICAL DRAWING (AUTOCAD)
SEMESTER/SESSION	: 2-2022/2023
DURATION	: 3 HOURS

Instructions:

1. This booklet contains **5** questions. Answer **ALL** questions.
2. All answers should be drawing in CAD File (**.dwg**).
3. Save your drawing files in to the created folder **22A1XXXX_FINAL_CADLABX_WSXX**. (20B0XXXX is your matrix number), (WSXX is your workstation number).
4. Write legibly and draw sketches wherever required.
5. If in doubt, raise your hands and ask the invigilator.

DO NOT OPEN THIS BOOKLET UNTIL YOU ARE TOLD TO DO SO

THIS BOOKLET CONTAINS 7 PRINTED PAGES INCLUDING COVER PAGE

Instruction:

Please ensure that all the answers to be saved together in **only one CAD file** and located at the Desktop in a folder. The folder name is: **22A1XXXX_FINAL_CADLABX_WSXX.**

All units are in millimeter (mm). Save drawing in CAD file (.dwg)

QUESTION 1

Reproduce the drawing as a Figure 1 as a standard:

- a) Object line (10 marks)
- b) Construction line (5 marks)
- c) Dimensioning (5 marks)

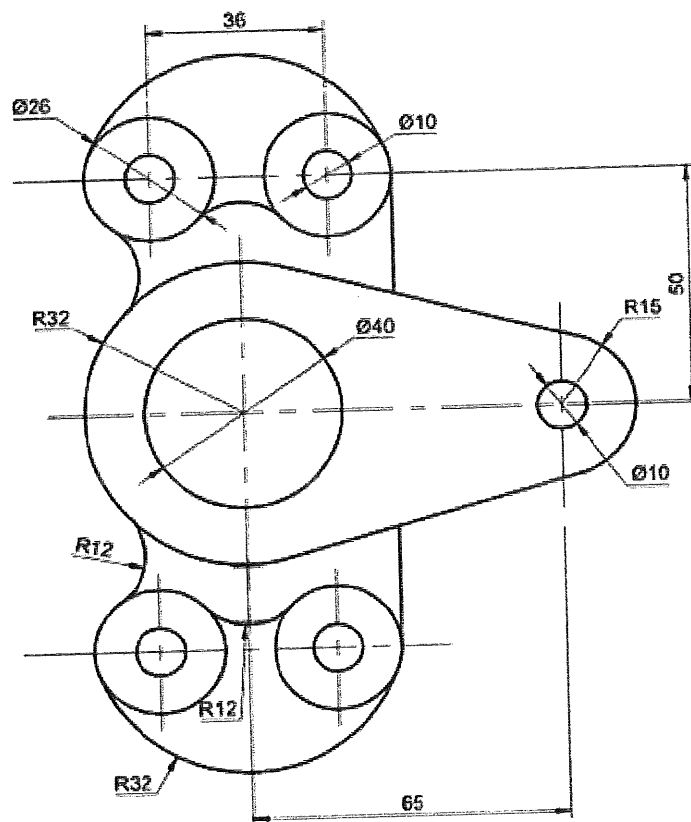

FIGURE 1

QUESTION 2

Reproduce the drawing as a Figure 2 as a standard:

- a) Object line (10 marks)
- b) Construction line (5 marks)
- c) Dimensioning (5 marks)

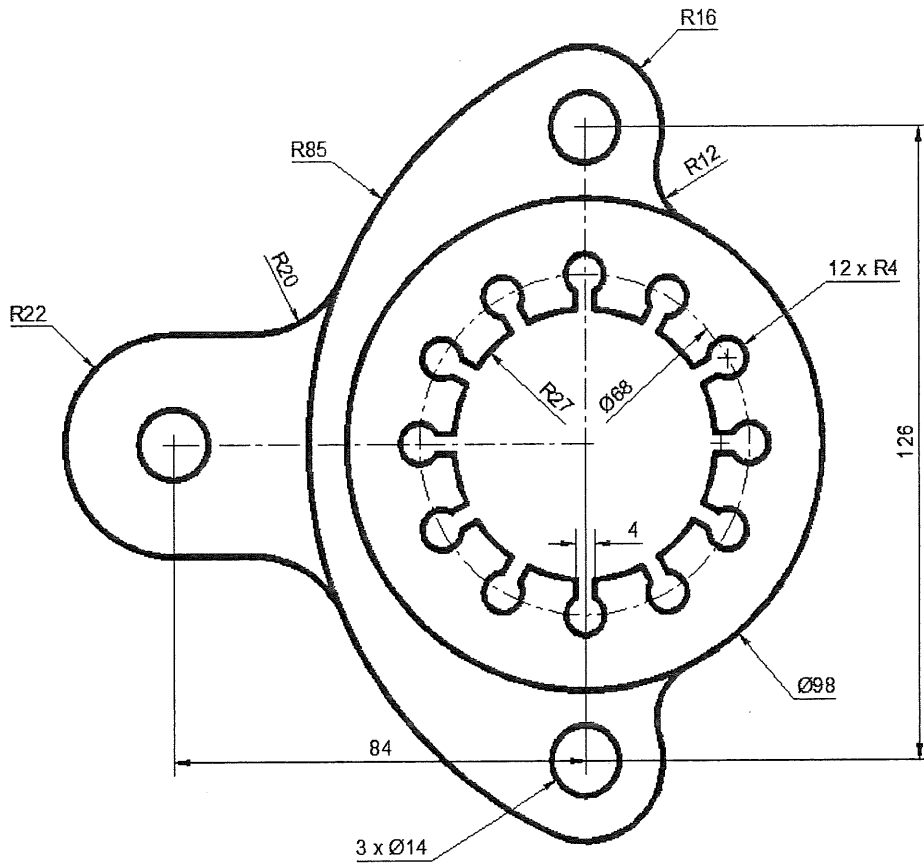

FIGURE 2

QUESTION 3

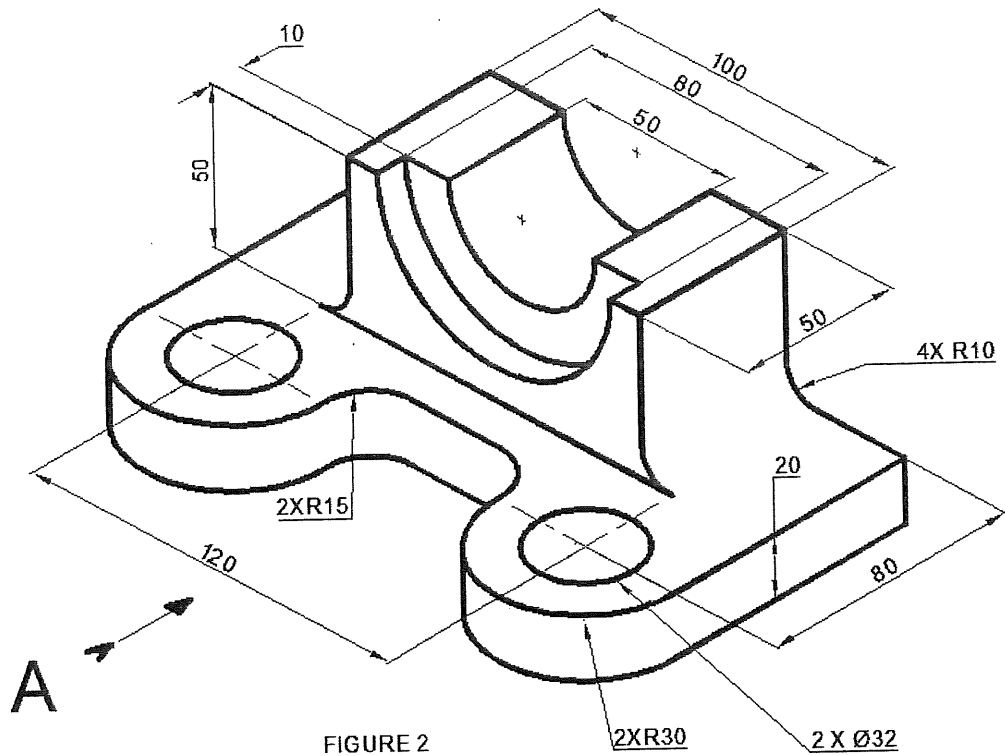
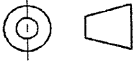

FIGURE 2

FIGURE 3

Figure 3 shows the isometric view of a part. **Construct** the part in full scale, using projection 

- a. Front view from direction A (5 marks)
- b. Top view (5 marks)
- c. Right side view (5 marks)
- d. Dimensioning (5 marks)

QUESTION 4

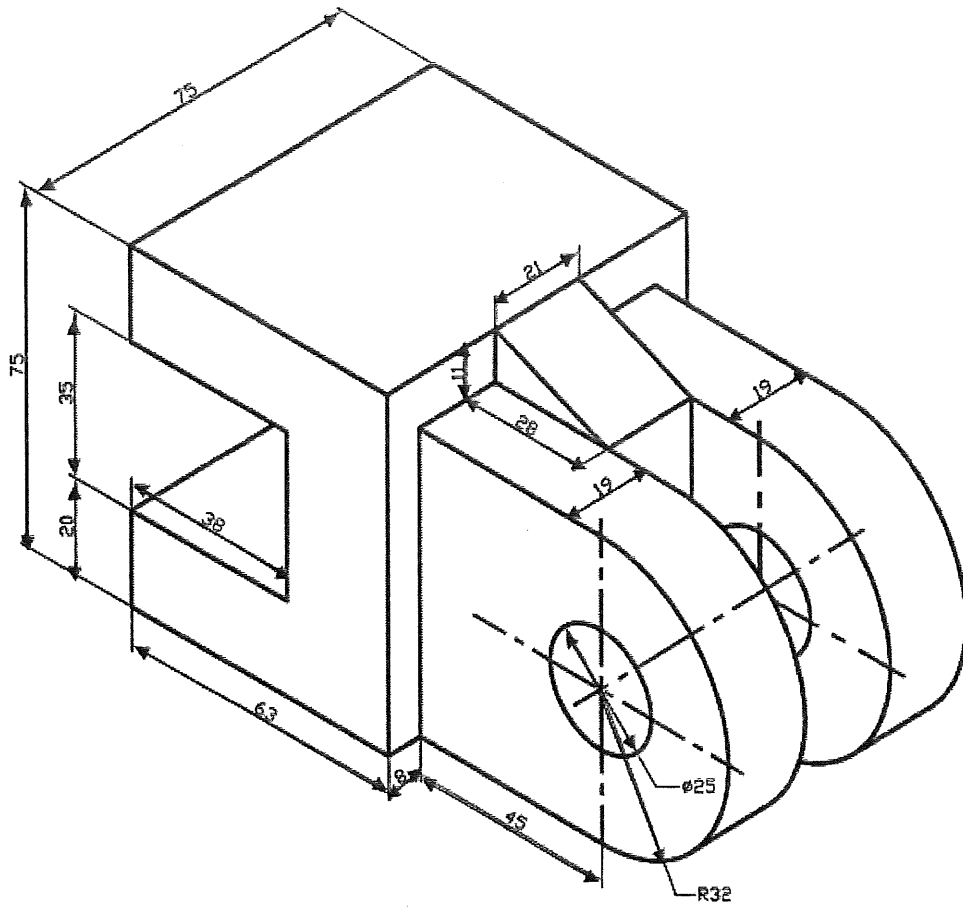

FIGURE 4

Figure 4 shows the isometric view of a part. **Illustrate** the part in full scale.

- a. Object (15 marks)
- b. Dimensioning (5 marks)

QUESTION 5

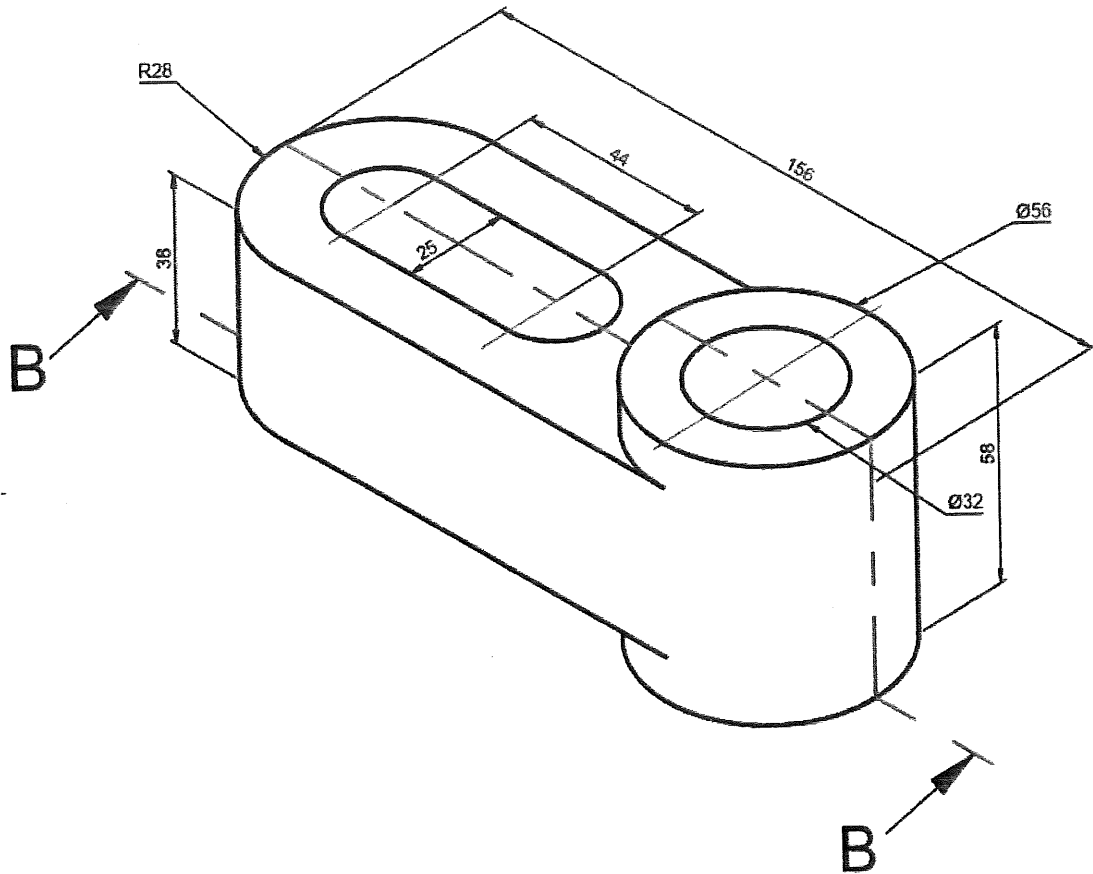



FIGURE 5

Figure 5 shows the isometric view of a part. **Construct** the part in full scale,

 using projection

- a. Front view from direction B (5 marks)
- b. Top view (5 marks)
- c. Right side view (5 marks)
- d. Dimensioning (5 marks)

-----End of questions-----

TECHNICAL DRAWING (DTD1013)

Criteria	Marks
All questions answered will be marked according to the answer schema	/100

